

### FEATURES

- Epitaxial planar die construction  
TRANSISTOR(NPN )

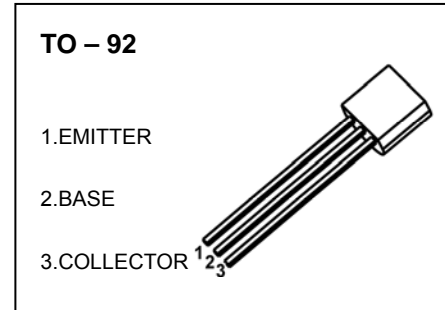

### MARKING

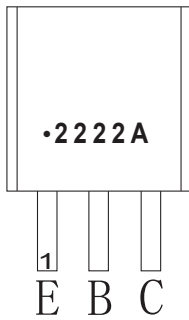

Solid dot=Green molding compound device,  
if none,the normal device  
XXX=Code

### Equivalent Circuit

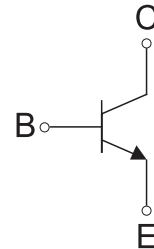

### MAXIMUM RATINGS (T<sub>a</sub>=25°C unless otherwise noted)

Symbol	Parameter	Value	Unit
V <sub>CBO</sub>	Collector-Base Voltage	75	V
V <sub>CEO</sub>	Collector-Emitter Voltage	40	V
V <sub>EBO</sub>	Emitter-Base Voltage	6	V
I <sub>C</sub>	Collector Current -Continuous	600	mA
P <sub>C</sub>	Collector Power Dissipation	625	mW
T <sub>J</sub>	Junction Temperature	150	°C
T <sub>stg</sub>	Storage Temperature	-55~+150	°C

### ELECTRICAL CHARACTERISTICS

T<sub>a</sub>=25 °C unless otherwise specified

Parameter	Symbol	Test conditions	Min	Max	Unit
Collector-base breakdown voltage	V <sub>(BR)CBO</sub>	I <sub>C</sub> = 10uA , I <sub>E</sub> =0	75		V
Collector-emitter breakdown voltage	V <sub>(BR)CEO</sub> *	I <sub>C</sub> = 10mA , I <sub>B</sub> =0	40		V
Emitter-base breakdown voltage	V <sub>(BR)EBO</sub>	I <sub>E</sub> = 10uA, I <sub>C</sub> =0	6		V
Collector cut-off current	I <sub>CBO</sub>	V <sub>CB</sub> = 60 V , I <sub>E</sub> =0		10	nA
Collector cut-off current	I <sub>CEX</sub>	V <sub>CE</sub> = 60 V , V <sub>EB(OFF)</sub> =3V		10	nA
Emitter cut-off current	I <sub>EBO</sub>	V <sub>EB</sub> = 3 V , I <sub>C</sub> =0		10	nA
DC current gain	h <sub>FE(1)</sub>	V <sub>CE</sub> =10 V , I <sub>C</sub> = 150mA	100	300	
	h <sub>FE(2)</sub>	V <sub>CE</sub> =10 V , I <sub>C</sub> = 0.1mA	40		
	h <sub>FE(3)</sub>	V <sub>CE</sub> =10 V , I <sub>C</sub> = 500mA	42		
Collector-emitter saturation voltage	V <sub>CE(sat)(1)</sub>	I <sub>C</sub> = 500mA, I <sub>B</sub> = 50mA		0.6	V
	V <sub>CE(sat)(2)</sub>	I <sub>C</sub> = 150mA, I <sub>B</sub> = 15mA		0.3	V
Base-emitter saturation voltage	V <sub>BE(sat)</sub>	I <sub>C</sub> = 500mA, I <sub>B</sub> = 50mA		1.2	V
Delay time	t <sub>d</sub>	V <sub>CC</sub> =30V, I <sub>C</sub> =150mA		10	ns
Rise time	t <sub>r</sub>	V <sub>BE(off)</sub> =-0.5V, I <sub>B1</sub> =15mA		25	
Storage time	t <sub>s</sub>	V <sub>CC</sub> =30V, I <sub>C</sub> =150mA		225	
Fall time	t <sub>f</sub>	I <sub>B1</sub> =- I <sub>B2</sub> = 15mA		60	
Transition frequency	f <sub>T</sub>	V <sub>CE</sub> =20 V, I <sub>C</sub> =20mA, f =100MHz	300		MHz

\* pulse test

#### CLASSIFICATION OF h<sub>FE(1)</sub>

Rank	L	H
Range	100-200	200-300

### TO-92 Package Outline Dimensions

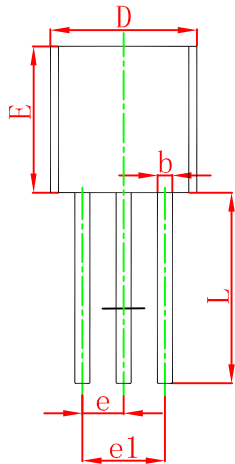
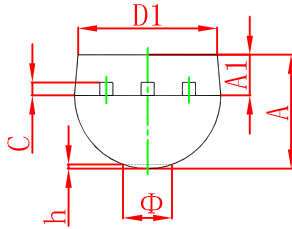

Symbol	Dimensions In Millimeters		Dimensions In Inches	
	Min	Max	Min	Max
A	3.300	3.700	0.130	0.146
A1	1.100	1.400	0.043	0.055
b	0.380	0.550	0.015	0.022
c	0.360	0.510	0.014	0.020
D	4.300	4.700	0.169	0.185
D1	3.430		0.135	
E	4.300	4.700	0.169	0.185
e	1.270 TYP		0.050 TYP	
e1	2.440	2.640	0.096	0.104
L	14.100	14.500	0.555	0.571
Φ		1.600		0.063
h	0.000	0.380	0.000	0.015

### TO-92 Suggested Pad Layout

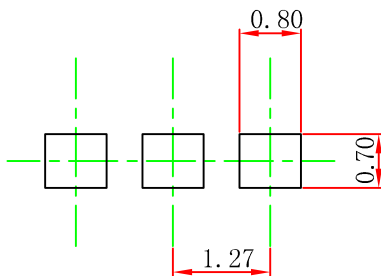

**Note:**

1. Controlling dimension: in millimeters.
2. General tolerance:  $\pm 0.05\text{mm}$ .
3. The pad layout is for reference purposes only.

**TO-92 PACKAGE TAPEING DIMENSION**

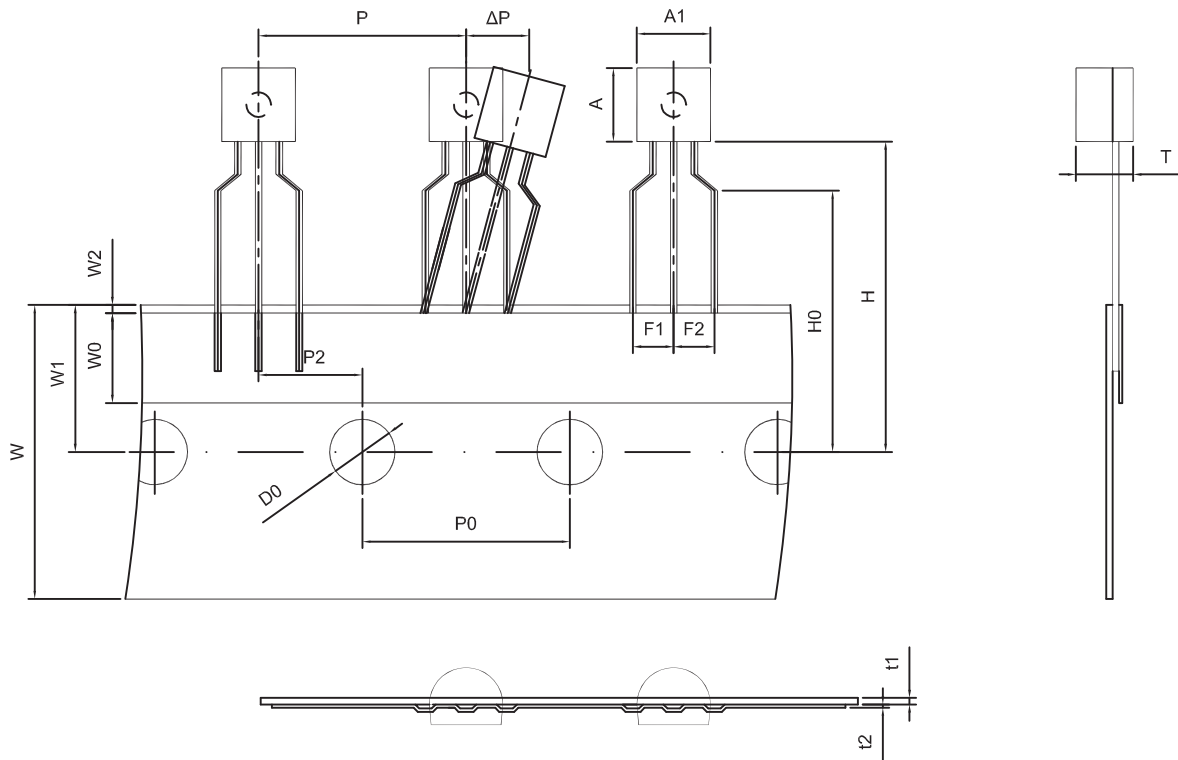

Dimensions are in millimeter								
A1	A	T	P	P0	P2	F1	F2	W
4.5	4.5	3.5	12.7	12.7	6.35	2.5	2.5	18.0
W0	W1	W2	H	H0	D0	t1	t2	ΔP
6.0	9.0	1.0 MAX.	19.0	16.0	4.0	0.4	0.2	0

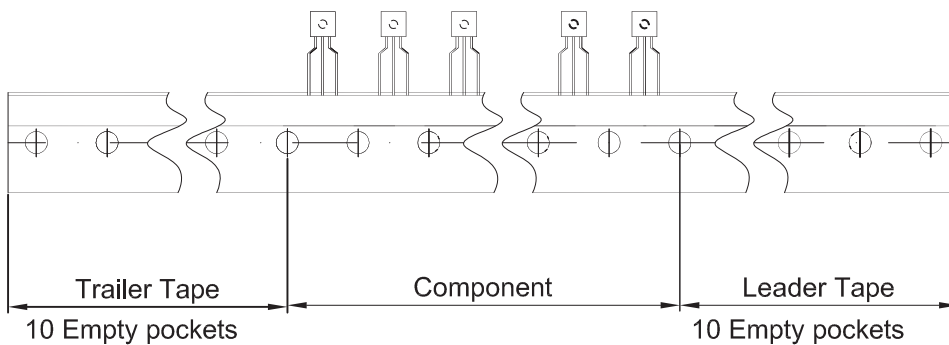

Package	Box	Box Size(mm)	Carton	Carton Size(mm)
TO-92	2000 pcs	333×162×43	20,000 pcs	350×340×250